

# 400 SERIES STANDARD DUTY STRAIGHT TRACK INSTALLATION INSTRUCTIONS

PLEASE READ INSTRUCTIONS THOROUGHLY  
BEFORE BEGINNING.

## A. BI-PARTING TRAVEL BATTEN INSTALLATION

1. Place track either on the floor or on sawhorses under the batten to which it will be attached. Make sure the tracks are overlapped the proper amount, 2'-0" is considered standard. Stage left track is always placed downstage. If track needs to be spliced, please refer to the section on splices in "Special Instructions."

2. Attach track at overlap with 1 set (two 405) overlap clamps approximately 6" from each end. Install hangers (406) evenly along the entire run of the track starting adjacent to end pulleys. Refer to recommended spacing provided. Additional hangers may be required due to site conditions. If the track is on the floor, installer may wish to attach the track to the batten and raise to a comfortable working level. Refer to step 5 for attachment instructions.

3. Attach end stops (409) to the onstage (center) ends of the track. From the offstage ends of the track, install one master carrier (402, 417, 419, or 429) into each track. Next, install single carriers (401, 416, 418, or 428) into each track behind the master (1 single carrier per foot of track).

4. Decide from which end the curtain will be operated. This is the side that the double end pulley (403, 423, or 433) will be attached. Attach pulley to end of track with chain bracket off to the side. After attaching the double end pulley, go to the opposite side of the track and install the single end pulley (404, 424, or 434). Make sure that end pulleys are installed in a manner similar to that indicated on the plan view detail in attached drawings.

5. Attach the track to the batten with either wire rope, welded link chain, or pipe clamps. Use attachment method appropriate to application. When using pipe clamps, a center pipe support (426) should be used to eliminate twisting through the overlap. **IMPORTANT!** Make sure track is parallel to floor before final attachment. **WARNING! After attaching track to batten, make sure to balance the line set and leave at a comfortable working level.**

6. Attaching a rope clamp to one end of operating line, reeve the **OTHER** end of line through the master carrier, single carriers, and through center sheave of double end pulley. When reeving operating line make sure that a rubber bumper is installed between each carrier.

7. Reeve line through the floor block (408, 422, or 432) or the sand bag tension pulley (643) and back over the other sheave of the double end pulley.

8. Next, the line travels toward the single end pulley. Reeve the line through the end stop & cord support, master carrier, single

carriers, and around the single end pulley. Make sure to put rope clamps on the operating line when going through the master carrier. **CAUTION! Do not tighten at this time.** The line travels through the other end stop & cord support and terminates where it started at the first master carrier. Place the line through the master and attach the rope clamp to the operating line leaving a small tail.

9. Make sure that all the slack in the line is on the double end pulley side (side with the floor block). Also make sure that there is sufficient line remaining to reach the intended finished height.

10. Slide each of the master carriers to the onstage (center) end stops. Now tighten each of the clamps on each master carrier. Raise the track to its desired height. Check to see that the floor block or sand bag tension pulley is taking the slack out of the operating line. Operate the track to make sure everything is running smoothly. If not, go through the entire system and check to make sure the components are installed properly.

11. The curtain may now be attached to the carriers. **WARNING! After attaching the curtain, the line set must be balanced. Always use caution when working with an out-of-balance line set.**

12. Raise the curtain and track to the desired height and adjust the floor tension block until the operating line has no slack in it. If a sand bag tension pulley is used, make sure the bag is filled with dry sand (not provided with sand bag) and the bag is securely attached to the steel housing.

## B. ONE-WAY TRAVEL BATTEN INSTALLATION

1. Place the track either on the floor or on sawhorses under the batten to which it will be attached. If track needs to be spliced, refer to the section on splices in "Special Instructions."

2. Install hangers (406) evenly along the entire run of the track starting adjacent to end pulleys. Refer to recommended spacing provided. Additional hangers may be required due to site conditions. If the track is on the floor, installer may wish to attach the track to the batten and raise to a comfortable working level. Refer to step 5 for attachment instructions.

3. Decide from which end the curtain will be operated. This is the side that the double end pulley (403, 423, or 433) will be attached. Do not attach the pulley to the end of the track at this time. Attach to the opposite side of the track the single end pulley (404, 424, or 434). Make sure that both end pulleys will be mounted in such a manner that both of the sheaves are on the same side of the track. The upstage side is preferred for cosmetic reasons.

4. From the double end pulley side of the track, install a master

carrier (402, 417, 419, or 429) into track. Next, install single carriers (401, 416, 418, or 428) into track behind the master (1 single carrier per foot of track). Finally, attach the double end pulley on the track.

5. Attach the track to the batten with either wire rope, welded link chain, or pipe clamps. Use method appropriate to application. **IMPORTANT!** Make sure track is parallel to the floor before final attachment. **WARNING! After attaching track to batten, make sure to balance the line set and leave at a comfortable working level.**

6. Attach a rope clamp to one end of operating line. Reeve the **OTHER** end of the line through the master carrier, single carriers, and through the center sheave of double end pulley. When reeving operating line make sure that a rubber bumper is installed between each carrier.

7. Reeve line through the floor block (408, 422, or 432) or the sand bag tension pulley (643) and back over the other sheave of the double end pulley.

8. Next, the line now travels to the single end pulley. Reeve around the single end pulley and back to the master carrier. Place the line through the master carrier and attach the rope clamp to the operating line leaving a small tail.

9. Raise the track to the desired height. Check to see that the floor block or sand bag tension pulley is taking the slack out of the operating line. Operate the track to make sure everything is running smoothly. If not, go through the entire system and check to make sure the components are installed properly.

10. The curtain may now be attached to the carriers. **WARNING! After attaching the curtain, the line set must be balanced. Always use caution when working with an out-of-balance line set.**

11. Raise the curtain and track to the desired height and adjust the floor tension block until the operating line has no slack in it. If a sand bag tension pulley is used, make sure the bag is filled with dry sand (not provided with sand bag) and the bag is securely attached to the steel housing.

## C. DEAD HUNG OR CEILING MOUNT INSTALLATION

### Before Beginning.

1. When installing a dead hung track, a decision must be made whether to install the track in sections or as a complete unit. Basis for this decision is the ability of the installer to lift and hold the track in place. The 410S track channel weighs 2.50 pounds per foot. (50 pounds for a 20'-0" length).

2. If installing on a ceiling, make careful measurements to determine if the ceiling is parallel to the floor. If not, shim the track accordingly. Also, take careful measurements in determining structural points in the ceiling to attach the track. Use appropriate hardware to attach the track to the ceiling based on roof structure and total track loads.

3. If track needs to be spliced with ceiling splice (427), splicing is sometimes easier if done on the floor or on sawhorses. The ceiling splice is a bolt through splice and care is needed to assure

that the carriers will still pass through the splice. **CAUTION! Wheels of 40 pivot device will not pass a 427 splice.**

## Dead Hung Installation

1. Determine where the hanging points for the track will be. Use either wire rope or welded link chain to hang track. Hanging points need to be at ends adjacent to end pulleys and evenly spaced along the entire run of the track. Refer to recommended spacing provided. Additional hangers may be required due to site conditions. Hanging method must be adjustable to allow for trimming the track parallel to floor.

2. Place track on the floor or on sawhorses in the exact location that the track will be positioned. If the track is overlapped, allow 2'-0" for this purpose. Place track hangers on track under hanging points.

3. Raise track in sections and attach to hanging points. Leveling the track in sections is suggested. If the track is overlapped, remember to attach the overlap clamps after both tracks are correctly positioned. Depending on curtain material, the track may need to be hung 1-3 inches higher than its finished height to allow for fabric stretch. After the curtain has been hung for a period of time, it may need to be re-trimmed.

4. Once the track has been hung and leveled, the track is rigged the same as a batten mounted track for either one-way or bi-parting (Steps 3,4 & 6-12).

## Ceiling Mount

1. After determining the condition of the ceiling and its relation to the floor, lay the track on the floor or on sawhorses in the position that it will be installed. Using a plumb line, mark and drill for attachment to ceiling under each structural support to which it will be attached.

2. Use a plumb line to determine the position of the track relative to the ceiling. Raise the track and use appropriate hanging method for job conditions. Make sure the track is parallel to the floor and provisions have been made to trim for curtain stretch.

3. After the track is installed, it is rigged in the same way as a batten mounted bi-parting or one-way track. (Steps 3,4 & 6-12).

**Note:** Clamp hangers and overlap clamps are not provided or used with ceiling mounted COMPLETE tracks.

## D. SPECIAL INSTRUCTIONS

### Splicing Track

1. In order to have a smooth operating track it is important that the track splices are installed properly and carefully. Do not over tighten the fasteners.

2. Make sure that the ends of the track are smooth and no jagged edges are protruding. Filing a slight downward bevel and rounding the corners will help form a smooth splice. If the track ends are not smooth, proper alignment may be impossible.

3. Loosen the splice and butt the track sections together in the splice. Tighten the four 3/8" splice attachment bolts (on top of

splice) until the track is held loosely. **CAUTION! Do not overtighten.**

4. Tighten the 1/4" adjustment screws on the top of the track until the track is seated firmly in the splice clamp. Next, tighten the other side of the splice in the same manner. Make sure that the track ends are still butted together. **CAUTION! Do not over tighten the bolts since deformation of the track is possible.**

5. The adjustment screws on the side of the splice are used to hold the side alignment of the track. Start by turning the screws on one side of the splice until they touch the track, then do the same to the other side. Any side misalignment may be adjusted by alternately tightening or loosening various screws.

6. When the track is aligned, tighten the 3/8" splice attachment bolts together. **Caution! Make sure that the track stays in alignment as you tighten the splice.**

**Pivot Devices**

1. Pivot devices allow for curtains to be positioned at different angles relative to the track. The 40, 40B, 40X, and 40XB are free-wheeling units. The addition of the optional 40BK and 40BKB brake kit will prevent undesired movement of pivot along track.

2. The pivot devices are designed for either 1-3/8" O.D. tubing or 1" Sch. 40 pipe. Maximum recommended batten length is 6'-0". Make sure that the batten is the proper length for the application.

3. Install the "C" clamps in each end of the curtain batten. These are provided so that a cord may be tied between the two to aid in turning the device. The cord should be long enough so that adjustment may be done with the curtain at its proper trim.

4. **WARNING! Tracks that include pivot devices must be provided with a bolt through style end stop (411) to contain the pivot device within the track assembly.**

4. **CAUTION! Do not attempt to adjust the curtain by means of pulling on the fabric. Damage to the curtain and associated hardware may result.**

5. **CAUTION! The recommended total load on the device must not exceed 75 pounds.**

**Rear Fold Guide**

1. Rear fold guides (412, 412A, or 413) are used when the curtain needs to store in a pocket or a "sliding door" effect is desired.

2. The guide is attached to the carrier and is positioned offstage in relation to the carrier. Rubber bumpers are place on each side of the guide to insure quiet operation. **Note:** The master carrier and carrier nearest the end pulley do not require a rear fold guide.

3. As the curtain is pulled open, it is pulled back into the pocket flat and does not start to fold until the carrier stops. The curtain does not billow as it moves offstage and will fold neatly in the pocket.

<b>RECOMMENDED TRACK SUPPORT SPACING Using 406 Clamp Hanger (in feet)</b>		
<b>Curtain Weight Per Carrier (pounds)</b>	<b>410A</b>	<b>410S</b>
2	8	10
3	8	10
4	8	10
5	8	10
6	8	10
7	7	9
10	7	8
15	5.5	5.5
20	4	4
25	3.5	3.5

For additional information, please refer to *Catalog Fourteen*, pages 62-63. For tracks 10 feet or less in length it is recommended that the track be supported at a minimum of three locations.

All recommendations stated are presented in good faith and based upon generally accepted engineering principles. The user, however, is cautioned that H & H Specialties Inc. cannot guarantee the accuracy of the data presented in this table for every situation. It is the customer's responsibility to determine the suitability of H & H Specialties' products for any given application, taking into account the specific requirements, the environment of use, and any possible peculiarities of the application.

Direct ceiling attachment of tracks has not been evaluated as the support structure, method of attachment, and attachment requirements may vary widely from project to project. A qualified person should be consulted for this application.

**DISCLAIMER**

This product is designed for moving curtains or, in some cases, scenery.

**NONE OF THE ITEMS DESCRIBED HEREIN ARE DESIGNED, INTENDED OR WARRANTED FOR THE USE OF LIFTING OR TRANSPORTING PEOPLE OR OTHER LIVING OBJECTS.**

H & H Specialties Inc. makes no representation of the suitability of any product for any application unless specific design drawings are made by the factory and the products are installed in precisely the manner detailed by our design staff.



# 400 SERIES HEAVY-DUTY STRAIGHT TRACK

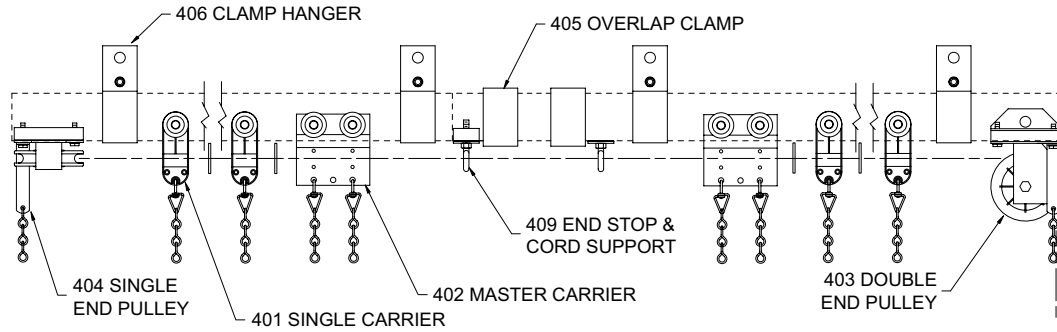

## COMPLETE TRACK MODEL NUMBERS

401A	401S	
416A	416S	416P
418A	418S	418P
428A	428S	

## BLACK COMPLETE TRACK MODEL NUMBERS

401SB	
416SB	416PB
418SB	418PB
428SB	

The 400 Series is a straight track offered in many models for a variety of project requirements. This heavy-duty track is available in galvanized steel, black powder-coated steel and mill finish aluminum. In addition to the traditional zinc plated finish, all hardware items are available in black finish to meet the demands of the theatrical industry.

Model 401S is recommended for moderately heavy curtains up to 60 feet in width. It utilizes ball bearing carriers with polyethylene wheels and 4" end pulleys. Model 428S is an economical upgrade to urethane wheels and 6" pulleys when a quiet track is desired for larger curtains.

Models 416S and 418S feature improved carriers with a custom designed, sealed ball bearing in each wheel. The 416 carrier is equipped with nylon-tired wheels for minimized friction when moving heavy loads. The 418 carrier has been redesigned with a urethane tire that combines durability with quiet operation. Each is complemented by 6" end pulleys for rigging curtains of virtually any length. The Premier versions, Models 416P and 418P, are the best in heavy-duty straight tracks. They incorporate 1/2" operating line, rear fold guides and 8" end pulleys for maximum ease of operation of very heavy stage curtains.

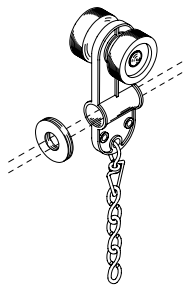

### SINGLE CARRIER

2 polyethylene wheels riveted to black Super Tough nylon body with shielded ball bearing. Heavy-duty hook, swivel, and trim chain for curtain attachment. Supplied with 1 rubber bumper.

No. 401 - Zinc plated.  
No. 401B - Black finish.

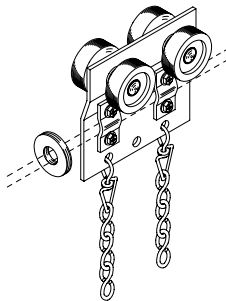

### MASTER CARRIER

4 polyethylene wheels riveted to steel body with 2 shielded ball bearings. 2 clamps provided for anchoring operating line or cable. Supplied with 1 rubber bumper. 1 pair required for overlapping tracks.

No. 402 - Zinc plated.  
No. 402B - Black finish.

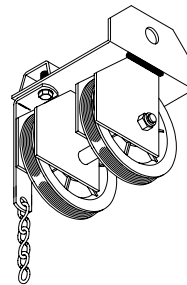

### DOUBLE END PULLEY

4" diameter Nylatron GS sheaves with shielded ball bearings. Steel housing clamps to underside of track. Chain bracket for securing offstage curtain edge. 3/8" groove.

No. 403 - Zinc plated.  
No. 403B - Black finish.

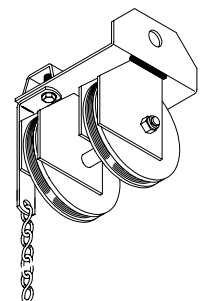

### No. 403M BLACK

### DOUBLE END PULLEY

Heavy-duty 4" diameter Nylatron GSM sheaves with sealed precision ball bearings. Steel housing clamps to underside of track. Chain bracket for securing offstage curtain edge. 3/16" groove for use with motorized tracks.

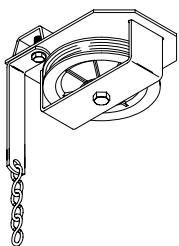

### SINGLE END PULLEY

4" diameter Nylatron GS sheave with shielded ball bearing. Steel housing clamps to underside of track. Chain bracket for securing offstage curtain edge. 3/8" groove.

No. 404 - Zinc plated.  
No. 404B - Black finish.

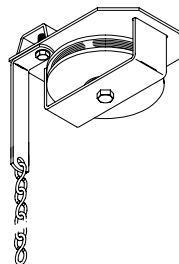

### No. 404M BLACK

### SINGLE END PULLEY

Heavy duty 4" diameter Nylatron sheave with sealed precision ball bearings. Steel housing clamps to underside of track. Chain bracket for securing offstage curtain edge. 3/16" groove for use with motorized tracks.

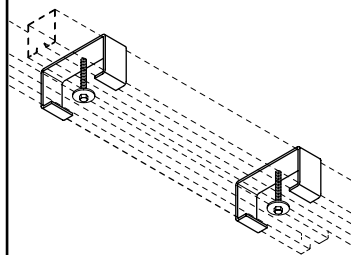

### OVERLAP CLAMP

Formed steel clamps to align track at overlap. 1 set pictured.

No. 405 - Zinc plated.  
No. 405B - Black finish.

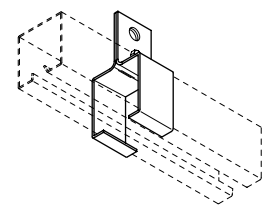

### CLAMP HANGER

Formed steel brackets clamp to track. Adjusts to any position. Suspend track with welded chain or wire rope. 1 pair pictured.

No. 406 - Zinc plated.  
No. 406B - Black finish.

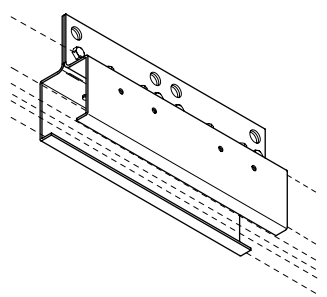

**SPLICE**  
Formed steel brackets align and lock track sections together. 1 pair pictured.  
**No. 407** - Zinc plated.  
**No. 407B** - Black finish.

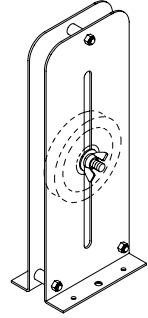

**No. 408 BLACK**  
**ADJUSTABLE FLOOR BLOCK**  
4" diameter Nylatron GS sheave with shielded ball bearing in steel housing.  
9" vertical adjustment.

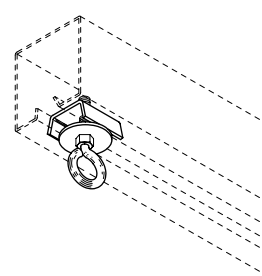

**END STOP & CORD SUPPORT**  
Steel clamp with eye to support operating line and prevent carriers from traveling beyond desired location. 1 pair required for overlapping tracks.  
**No. 409** - Zinc plated.  
**No. 409B** - Black finish.

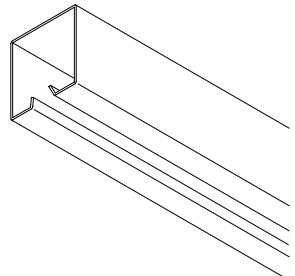

**No. 410A TRACK**  
Mill finish 6063-T5 extruded aluminum 2-5/8" wide x 2-3/4" high, .080" thick. 20' and 24' stock lengths.

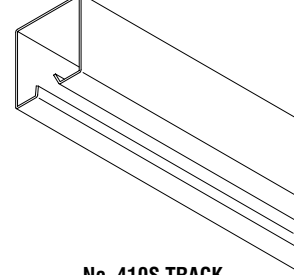

**No. 410S TRACK**  
14 gauge galvanized steel, roll-formed to 2-5/8" wide x 2-3/4" high.  
**No. 410S-** 16', 20', 24', and 26' stock lengths.  
**No. 410S-B-** Semi-gloss black powder coat finish. 20', and 24' stock lengths.

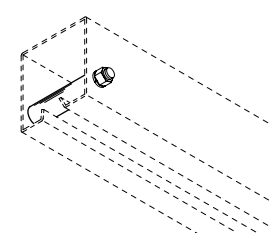

**END STOP**  
Bolt with steel spacer to prevent carriers from travelling beyond desired location. For use with walk-along tracks.  
**No. 411** - Zinc plated.  
**No. 411B** - Black finish.

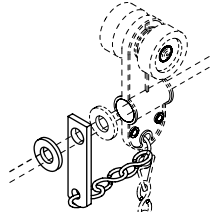

**REAR FOLD GUIDE**  
Allows curtain to fold at offstage edges. Supplied with 1 rubber bumper.  
**No. 412** - for use with 3/8" operating line.  
**NO. 412B** - same as 412 in Black  
**No. 412A** - for use with 1/2" operating line. Black finish.  
**No. 413** - for use with 3/16" operating cable.  
**No. 413B** - same as 413 in Black

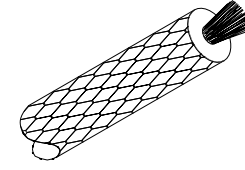

**No. 414 OPERATING LINE**  
3/8" diameter black polyester braided over solid aramid core for manual operation.

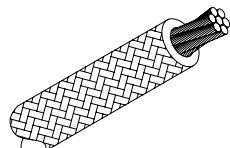

**No. 415 OPERATING CABLE**  
3/16" diameter black polyester jacket braided over 3/32" galvanized aircraft cable. For use with motorized tracks.

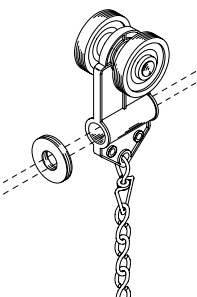

**No. 416 BLACK SINGLE CARRIER**  
2 nylon-tired sealed ball bearing wheels riveted to black Super Tough nylon body with heavy-duty hook, swivel and 6" trim chain for curtain attachment. Supplied with 1 rubber bumper.

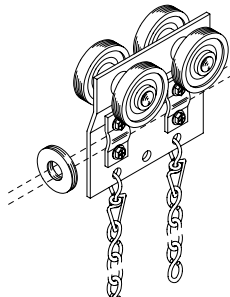

**No. 417 BLACK MASTER CARRIER**  
4 nylon-tired sealed ball bearing wheels riveted to steel body. 2 clamps provided for anchoring operating line or cable. Supplied with 1 rubber bumper. 1 pair required for overlapping tracks.

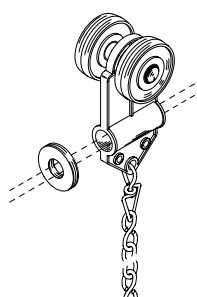

**No. 418 BLACK SINGLE CARRIER**  
2 urethane-tired sealed ball bearing wheels riveted to black Super Tough nylon body with heavy-duty hook, swivel and 6" trim chain for curtain attachment. Supplied with 1 rubber bumper.

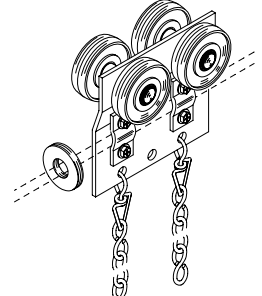

**No. 419 BLACK MASTER CARRIER**  
4 urethane-tired sealed ball bearing wheels riveted to steel body. 2 clamps provided for anchoring operating line or cable. Supplied with 1 rubber bumper. 1 pair required for overlapping tracks.

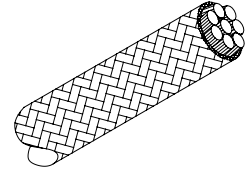

**No. 420 OPERATING LINE**  
1/2" diameter black spun polyester braided over polyester core for manual operation.

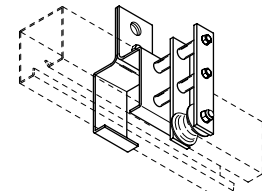

**CLAMP HANGER WITH IDLER**  
No. 406 clamp hanger with Nylatron GS ball bearing roller for supporting operating line or cable.  
**NO. 421** - Zinc plated.  
**NO. 421B** - Black finish.

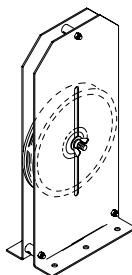

**No. 422, BLACK 8" ADJUSTABLE FLOOR BLOCK**  
8" diameter Nylatron GS sheave with sealed precision ball bearings in heavy-duty steel housing with 9" vertical adjustment. Grooved to accept up to 1/2" operating line.

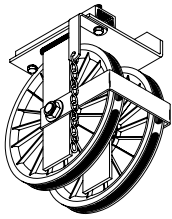

**BLACK 8" DOUBLE END PULLEY**

8" diameter Nylatron GS sheaves with sealed precision ball bearings. Heavy-duty steel housing clamps to underside of track. Chain bracket for securing offstage curtain edge.

**No. 423** - Grooved for up to 1/2" operating line.  
**No. 423M** - Grooved for 3/16" operating cable.

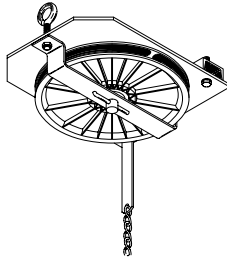

**BLACK 8" SINGLE END PULLEY**

8" diameter Nylatron GS sheave with sealed precision ball bearings. Heavy-duty steel housing clamps to underside of track. Chain bracket for securing offstage curtain edge.

**No. 424** - Grooved for up to 1/2" operating line.  
**No. 424M** - Grooved for 3/16" operating cable.

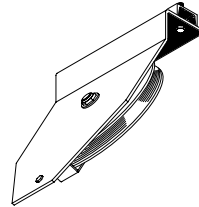

**424A BLACK 8" SLANTED SINGLE END PULLEY**

8" diameter Nylatron GS sheave with sealed precision ball bearings. Heavy-duty steel housing clamps to underside of track. Chain bracket for securing offstage curtain edge. Grooved for up to 1/2" operating line. Allows a narrower profile when installed.

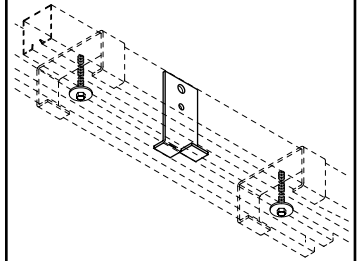

**CENTER PIPE SUPPORT**

Formed steel bracket used to support tracks at overlap.

**No. 426** - Zinc plated.  
**No. 426B** - Black finish.

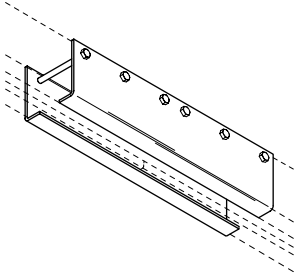

**CEILING SPLICE**

To align and lock track sections together on ceiling mounted tracks. 1 pair pictured.

**Note:** Cannot be used with No. 40 pivot device.

**No. 427** - Zinc plated.  
**No. 427B** - Black finish.

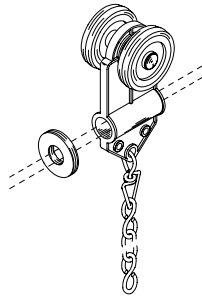

**No. 428 BLACK SINGLE CARRIER**

2 urethane-tired wheels riveted to black Super Tough nylon body with shielded ball bearing. Heavy-duty hook, swivel and 6" trim chain for curtain attachment. Supplied with 1 rubber bumper.

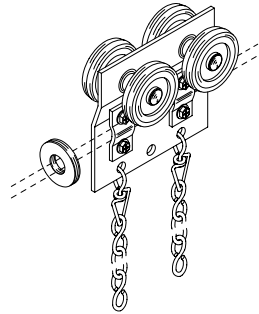

**NO. 429 BLACK MASTER CARRIER**

4 urethane-tired wheels riveted to steel body with 2 shielded ball bearings. 2 clamps provided for anchoring operating line or cable. Supplied with 1 rubber bumper. 1 pair required for overlapping tracks.



**ROUND RUBBER BUMPER**

1/8" neoprene bumper placed between carriers to reduce noise.

**No. 430** - for use with 3/16" operating cable.  
**No. 431** - for use with 3/8" operating line.  
**No. 431A** - for use with 1/2" operating line.

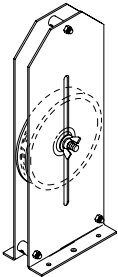

**No. 432, BLACK 6" ADJUSTABLE FLOOR BLOCK**

6" diameter Nylatron GS sheave with sealed precision ball bearings in heavy-duty steel housing with 9" vertical adjustment. Grooved to accept up to 1/2" operating line.

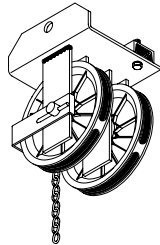

**6" BLACK DOUBLE END PULLEY**

6" diameter Nylatron GS sheaves with precision sealed ball bearings. Heavy-duty steel housing clamps to underside of track. Chain bracket for securing offstage curtain edge.

**No. 433** - Grooved for up to 1/2" operating line.  
**No. 433M** - Grooved for 3/16" operating cable.

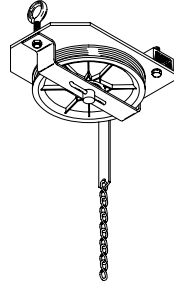

**6" BLACK SINGLE END PULLEY**

6" diameter Nylatron GS sheave with sealed precision ball bearings. Heavy-duty steel housing clamps to underside of track. Chain bracket for securing offstage curtain edge.

**No. 434** - Grooved for up to 1/2" operating line.  
**No. 434M** - Grooved for 3/16" operating cable.

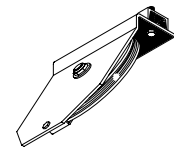

**434A BLACK 6" SLANTED SINGLE END PULLEY**

6" diameter Nylatron GS sheave with sealed precision ball bearings. Heavy duty steel housing clamps to underside of track. Chain bracket for securing offstage curtain edge. Grooved for up to 1/2" operating line. Allows a narrower profile when installed.

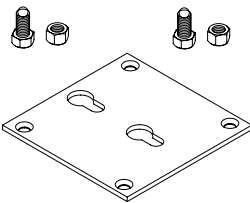

**BLACK DETACHABLE FLOOR BLOCK KIT**

7 gauge steel plate with hardware for use with floor block for quick release.

**No. 408DK** - use with No. 408 4" Floor Block.  
**No. 422DK** - use with No. 422 8" Floor Block.  
**No. 432DK** - use with No. 432 6" Floor Block.

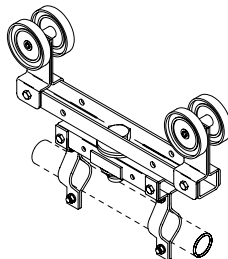

**40 PIVOT DEVICE**

Heavy steel construction with nylon wheels. Supplied with brackets for 1-3/8" O.D. pipe or tubing (6' max. recommended length). Allows masking draperies to be rotated to any angle. Working Load Limit: 75 pounds.

**No. 40** - Zinc plated.  
**No. 40B** - Black finish.

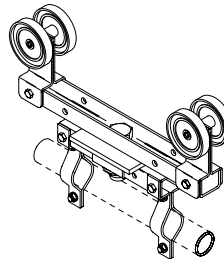

**INDEXING PIVOT DEVICE**

Pivot device with special plate to index rotation at 22-1/2 degree increments. Supplied with brackets for 1-3/8" O.D. pipe or tubing (6' max. recommended length). Working Load Limit: 75 pounds.

**No. 40X** - Zinc plated.  
**No. 40XB** - Black finish.

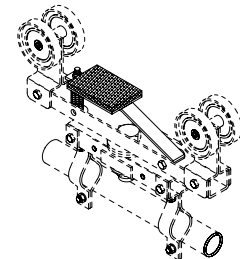

**BRAKE KIT**

Spring equipped arm with neoprene pad. Add to pivot device to prevent undesired movement along track.

**No. 40BK** - Zinc plated.  
**No. 40BKB** - Black finish.



## 400 SERIES COMPLETE TRACK COMPONENT GUIDE

PART No.	DESCRIPTION	401S	416S	416P	418S	418P	428S
401	Single Carrier	•					
402	Master Carrier	•					
403	4" Double End Pulley	•					
404	4" Single End Pulley	•					
405	Overlap Clamp	•	•	•	•	•	•
406	Clamp Hanger	•	•	•	•	•	•
407*	Splice	•	•	•	•	•	•
408	Black 4" Adjustable Floor Block	•					
409	End Stop & Cord Support	•	•	•	•	•	•
410S*	Track	•	•	•	•	•	•
412A	Black 1/2" Rear Fold Guide			•		•	
414	3/8" Operating Line	•	•		•		•
416	Black Nylon B.B. Single Carrier		•	•			
417	Black Nylon B.B. Master Carrier		•	•			
418	Black Urethane B.B. Single Carrier				•	•	
419	Black Urethane B.B. Master Carrier				•	•	
420	1/2" Operating Line			•		•	
422	Black 8" Adjustable Floor Block			•		•	
423	Black 8" Double End Pulley			•		•	
424	Black 8" Single End Pulley			•		•	
428	Black Urethane Single Carrier						•
429	Black Urethane Master Carrier						•
432	Black 6" Adjustable Floor Block		•		•		•
433	Black 6" Double End Pulley		•		•		•
434	Black 6" Single End Pulley		•		•		•

\* Track lengths and splices supplied as required from stock sizes.

For COMPLETE tracks supplied with aluminum, substitute 410A for 410S.

## 400 SERIES BLACK COMPLETE TRACK COMPONENT GUIDE

Note: Aluminum track is not offered in black.

PART No.	DESCRIPTION	401SB	416SB	416PB	418SB	418PB	428SB
401B	Black Single Carrier	•					
402B	Black Master Carrier	•					
403B	Black 4" Double End Pulley	•					
404B	Black 4" Single End Pulley	•					
405B	Black Overlap Clamp	•	•	•	•	•	•
406B	Black Clamp Hanger	•	•	•	•	•	•
407B*	Black Splice	•	•	•	•	•	•
408	Black 4" Adjustable Floor Block	•					
409B	Black End Stop & Cord Support	•	•	•	•	•	•
410S-B*	Black Track	•	•	•	•	•	•
412A	Black 1/2" Rear Fold Guide			•		•	
414	3/8" Operating Line	•	•		•		•
416	Black Nylon B.B. Single Carrier		•	•			
417	Black Nylon B.B. Master Carrier		•	•			
418	Black Urethane B.B. Single Carrier				•	•	
419	Black Urethane B.B. Master Carrier				•	•	
420	1/2" Operating Line			•		•	
422	Black 8" Adjustable Floor Block			•		•	
423	Black 8" Double End Pulley			•		•	
424	Black 8" Single End Pulley			•		•	
428	Black Urethane Single Carrier						•
429	Black Urethane Master Carrier						•
432	Black 6" Adjustable Floor Block		•		•		•
433	Black 6" Double End Pulley		•		•		•
434	Black 6" Single End Pulley		•		•		•

\* Track lengths and splices supplied as required from stock sizes.



## GENERAL SPECIFICATIONS: HEAVY DUTY STRAIGHT TRACK

---

Provide **Model 401S** as manufactured by H & H Specialties Inc., South El Monte, CA.

Track shall be 14 gauge galvanized steel, roll-formed to 2-5/8" wide X 2-3/4" high channel with continuous slot in bottom. Provide unspliced in lengths up to 26'.

Suspend track with two-piece clamp hanger formed from 11 gauge steel. Provide 2' overlap at center, rigidly separated by two overlap clamps. Install end stop with cord support at each track end. Where lengths exceed 26', connect tracks with 12" long, two-piece splicing clamp of 12 gauge steel.

Provide single carriers, spaced on 12" centers, constructed of two polyethylene wheels fastened parallel to carrier body. Supply with heavy-duty hook, swivel eye and trim chain for attachment of curtain. Black Super Tough nylon shall be molded around shielded and greased ball bearing to form carrier body. Install round neoprene bumper between each carrier to reduce noise.

Master carriers shall be 4-wheel assemblies with bodies formed from 11 gauge steel with press-fit ball bearings. Connect to operating line with two formed steel cord clamps attached to each body. Supply each master carrier with two heavy-duty hooks, swivel eyes and trim chains for attachment of leading edge of curtain.

Single and double end pulleys shall clamp securely to the underside of the track channel and shall contain 4" diameter sheaves enclosed in steel housings to prevent operating line from escaping the grooves. Sheaves shall be Nylatron GS molded around shielded and greased ball bearings and grooved to accommodate up to 3/8" operating line.

Provide floor block in 12 gauge steel housing containing 4" Nylatron GS shielded ball bearing sheave. Sheave axle shall lock at any point within 9" vertical slots to allow tension adjustment of operating line.

Black operating line shall be 3/8" diameter, stretch-resistant rope with spun polyester outer jacket braided over solid aramid core.

All steel components shall be zinc plated to resist corrosion.

---

Provide **Model 416S** as manufactured by H & H Specialties Inc., South El Monte, CA.

Track shall be 14 gauge galvanized steel, roll-formed to 2-5/8" wide X 2-3/4" high channel with continuous slot in bottom. Provide unspliced in lengths up to 26'.

Suspend track with two-piece clamp hanger formed from 11 gauge steel. Provide 2' overlap at center, rigidly separated by two overlap clamps. Install end stop with cord support at each track end. Where lengths exceed 26', connect tracks with 12" long, two-piece splicing clamp of 12 gauge steel.

Provide single carriers, spaced on 12" centers, constructed of two nylon-tired sealed ball bearing wheels fastened parallel to black Super Tough nylon carrier body. Supply with heavy-duty hook, swivel eye and 6" trim chain for attachment of curtain. Install round neoprene bumper between each carrier to reduce noise.

Master carriers shall be 4-wheel nylon-tired sealed ball bearing assemblies with bodies formed from 11 gauge steel. Connect to operating line with two formed steel cord clamps attached to each body. Supply each master carrier with two heavy-duty hooks, swivel eyes and 6" trim chains for attachment of leading edge of curtain.

Single and double end pulleys shall clamp securely to the underside of the track channel and shall be equipped with 6" diameter Nylatron GS sheaves grooved for up to 1/2" operating line. Install two 5/8" sealed precision ball bearings in each sheave. Lock shaft to side plate on head end with 3/16" keeper pin to prevent rotation and install fine-threaded nylon insert lock nut.

Provide floor block in 12 gauge steel housing containing 6" Nylatron sheave with two 3/8" sealed precision ball bearings. Sheave axle shall lock at any point within 9" vertical slots to allow tension adjustment of operating line.

Black operating line shall be 3/8" diameter, stretch-resistant rope with spun polyester outer jacket braided over solid aramid core.

All steel components shall be zinc plated to resist corrosion.

---

Provide **Model 418P** as manufactured by H & H Specialties Inc., South El Monte, CA.

Track shall be 14 gauge galvanized steel, roll-formed to 2-5/8" wide X 2-3/4" high channel with continuous slot in bottom. Provide unspliced in lengths up to 26'.

Suspend track with two-piece clamp hanger formed from 11 gauge steel. Provide 2' overlap at center, rigidly separated by two overlap clamps. Install end stop with cord support at each track end. Where lengths exceed 26', connect tracks with 12" long, two-piece splicing clamp of 12 gauge steel.

Provide single carriers, spaced on 12" centers, constructed of two urethane-tired sealed ball bearing wheels fastened parallel to black Super Tough nylon carrier body. Supply with heavy-duty hook, swivel eye and 6" trim chain for attachment of curtain. Install rear fold guide and two round neoprene bumpers between each carrier to fold curtain at offstage edges and minimize noise.

Master carriers shall be 4-wheel urethane-tired sealed ball bearing assemblies with bodies formed from 11 gauge steel. Connect to operating line with two formed steel cord clamps attached to each body. Supply each master carrier with two heavy-duty hooks, swivel eyes and 6" trim chains for attachment of leading edge of curtain.

Single and double end pulleys shall clamp securely to the underside of the track channel and shall be equipped with 8" diameter Nylatron GS sheaves grooved for 1/2" operating line. Install two 5/8" sealed precision ball bearings in each sheave. Lock shaft to side plate on head end with 3/16" keeper pin to prevent rotation and install fine-threaded nylon insert lock nut.

Provide floor block in 12 gauge steel housing containing 8" Nylatron sheave with two 3/8" sealed precision ball bearings. Sheave axle shall lock at any point within 9" vertical slots to allow tension adjustment of operating line.

Black operating line shall be 1/2" diameter, stretch-resistant rope with spun polyester outer jacket braided over polyester core.

All steel components shall be zinc plated to resist corrosion.



# 401S TRACK

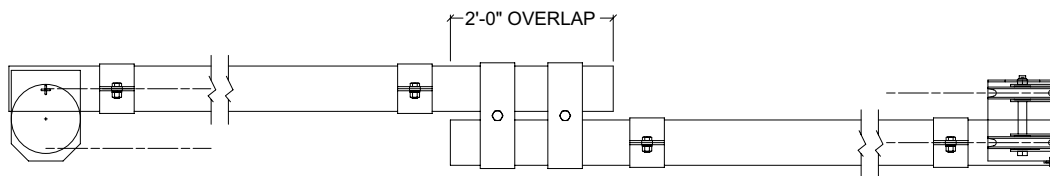

PLAN - MODEL 401S COMPLETE TRACK

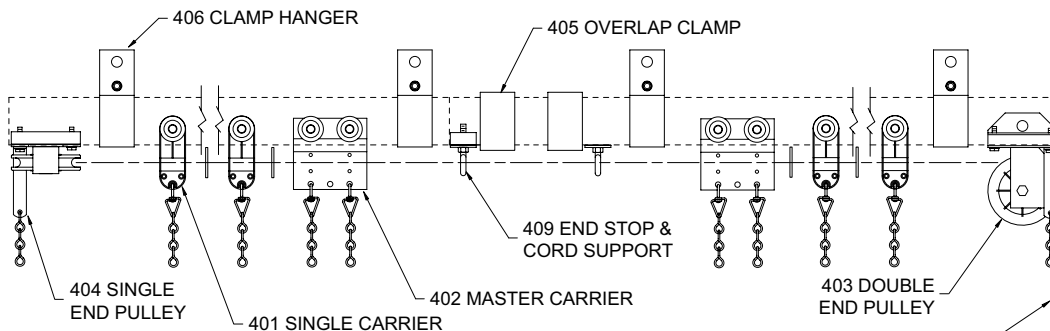

ELEVATION - MODEL 401S COMPLETE TRACK

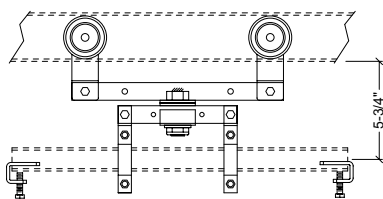

40 PIVOT DEVICE

414 OPERATING LINE

408 BLACK ADJUSTABLE FLOOR BLOCK

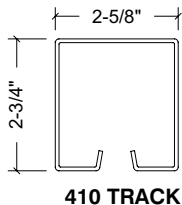

410 TRACK

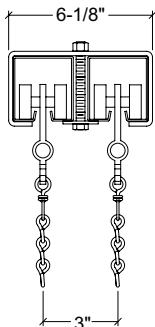

TRACKS AT CENTER OVERLAP

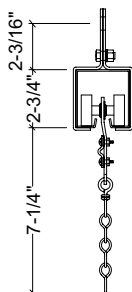

401 SINGLE CARRIER AND 402 MASTER CARRIER

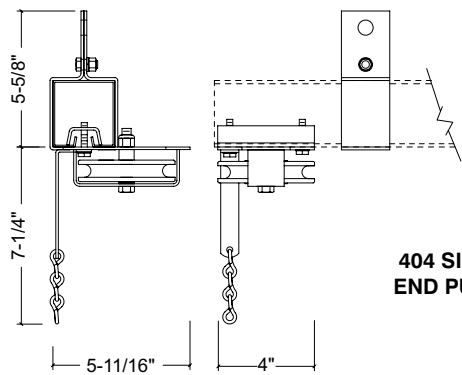
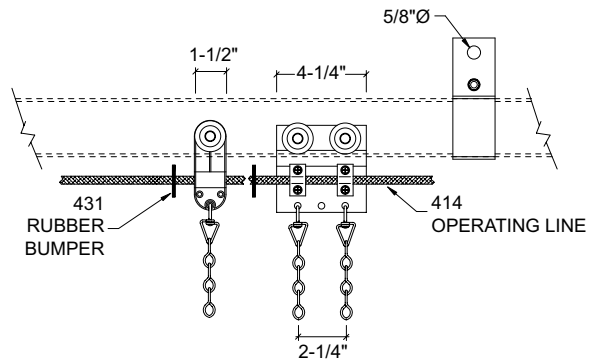

404 SINGLE END PULLEY

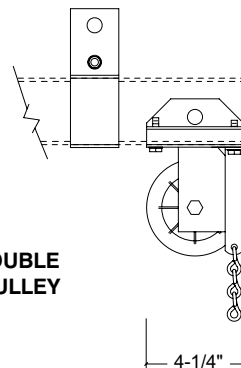

403 DOUBLE END PULLEY

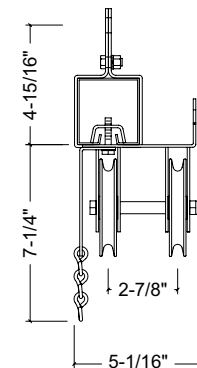



# 416S TRACK

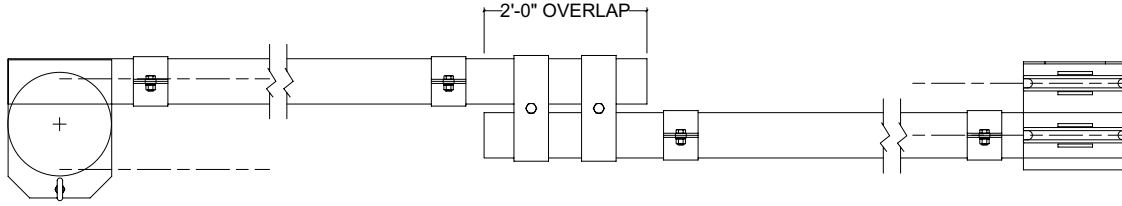

PLAN - MODEL 416S COMPLETE TRACK

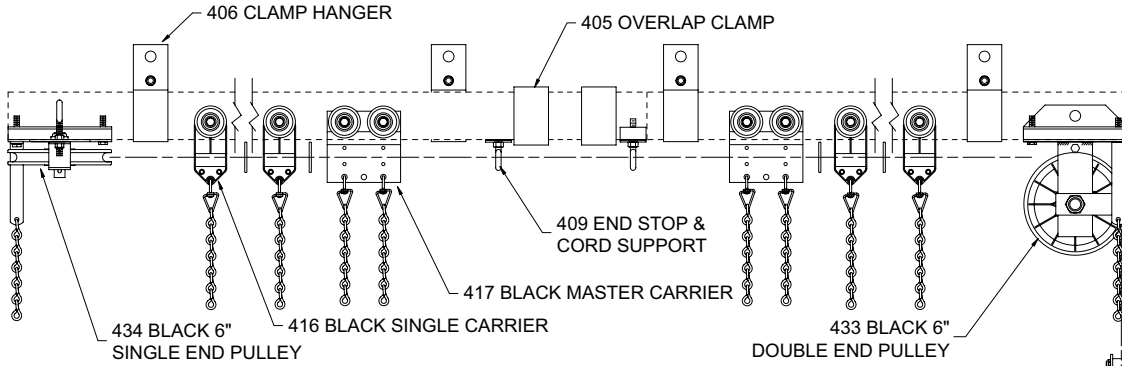

ELEVATION - MODEL 416S COMPLETE TRACK

NOTE: 418S dimensions similar.

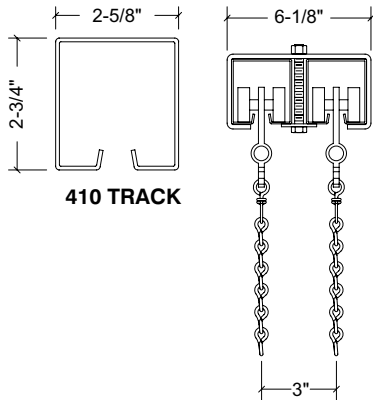
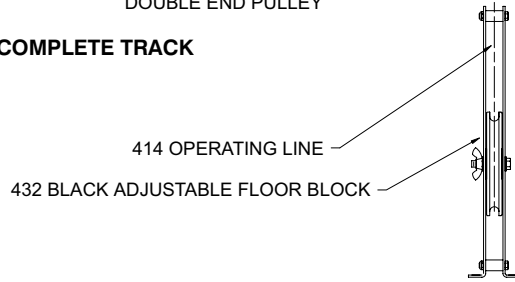

410 TRACK

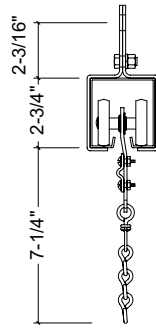

416 BLACK SINGLE CARRIER AND 417 BLACK MASTER CARRIER

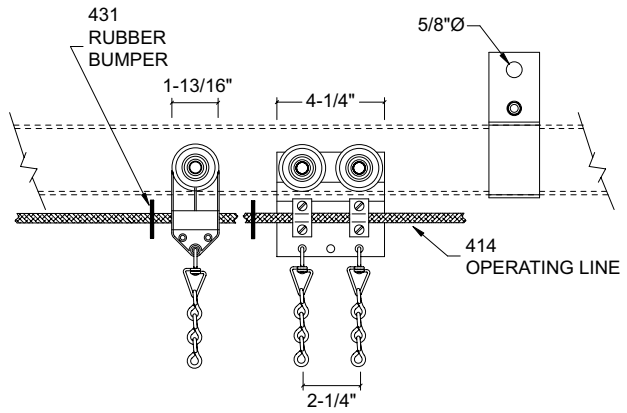

TRACKS AT CENTER OVERLAP

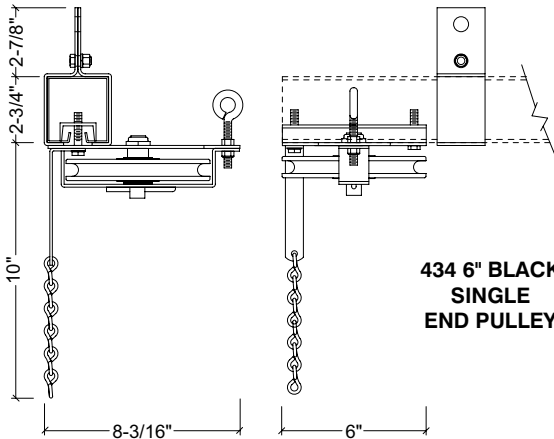

434 6" BLACK SINGLE END PULLEY

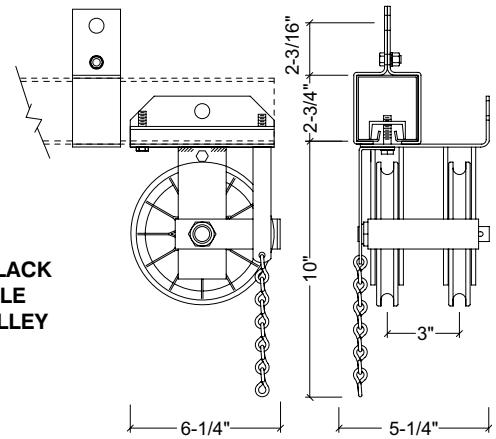

433 6" BLACK DOUBLE END PULLEY

# 418P TRACK

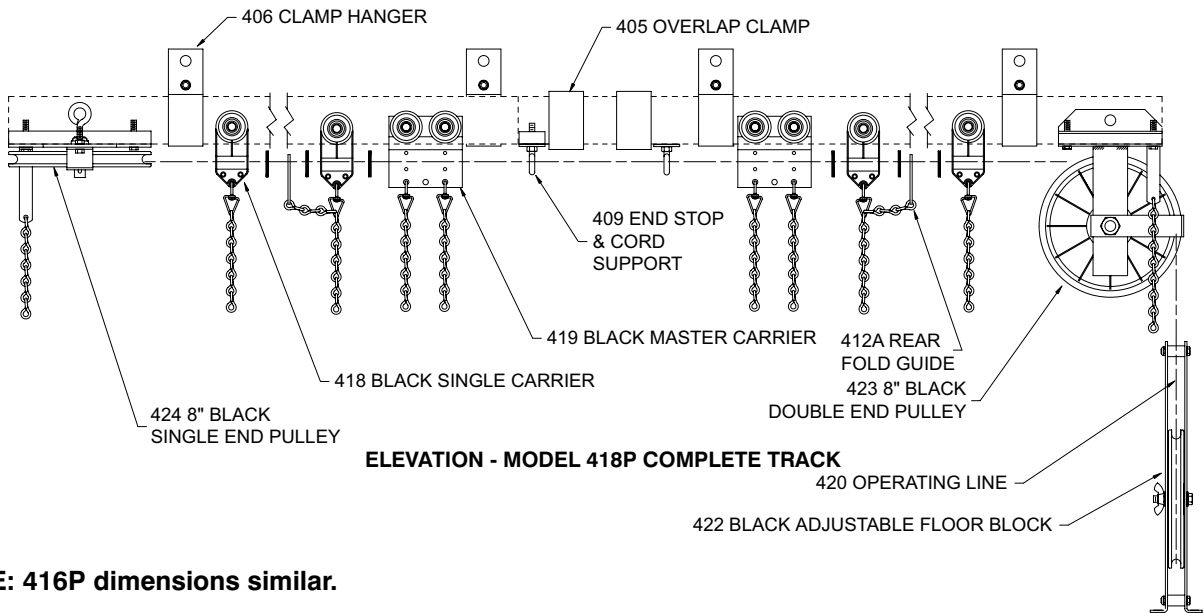
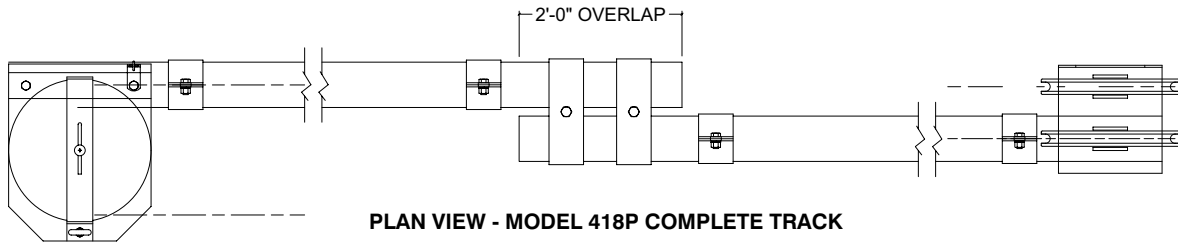

**NOTE: 416P dimensions similar.**

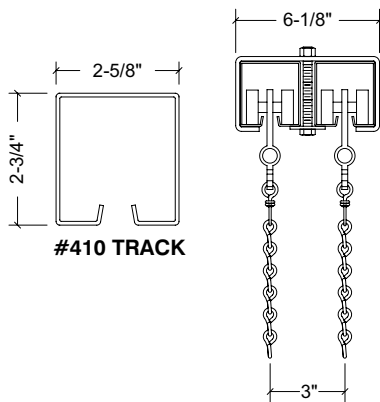

**TRACKS AT CENTER OVERLAP**

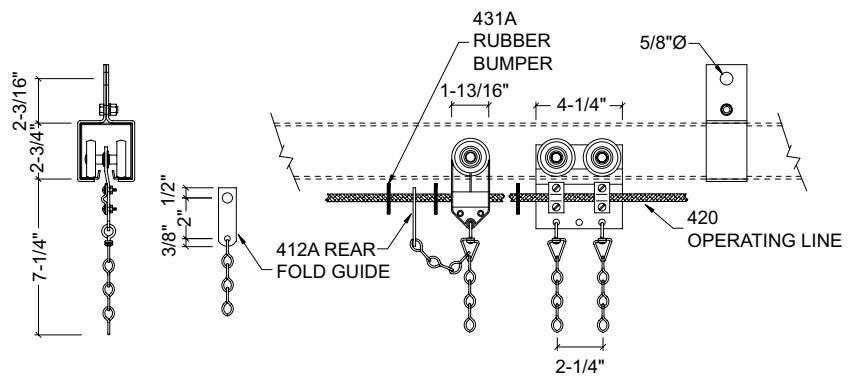

**418 BLACK SINGLE CARRIER AND 419 BLACK MASTER CARRIER**

