

H & H Specialties Inc.

manufacturer of stage equipment

Orpheum Theatre, Phoenix, Arizona Photo Credit: Gary Quesada, Hedrick Blessing



Teatro Zarragoza, Six Flags Fiesta Texas

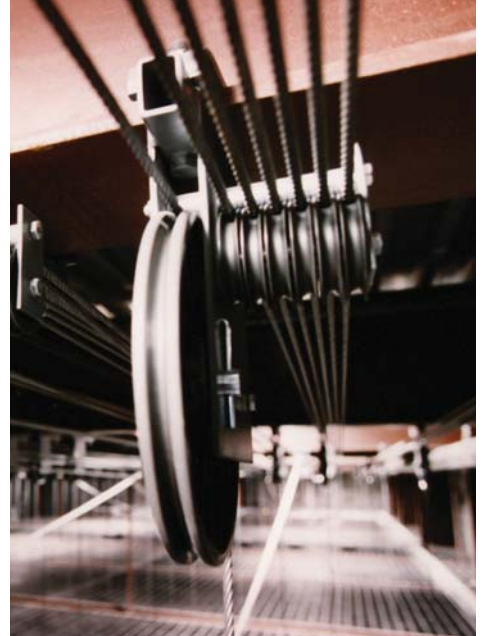

Kentucky Educational Television Facility, Lexington, Kentucky Photo Credit: Richard J. Nix













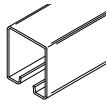

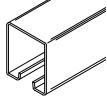

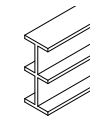

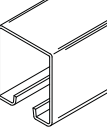
Seegerstrom Hall © 2007 Lawrence Anderson/LawrenceAnderson.net

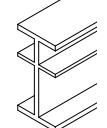
H & H Specialties has manufactured stage curtain tracks and rigging equipment for entertainment and performing arts facilities for over 50 years under the Atlas Silk® trademark. During this time, users have come to expect their equipment to accommodate increased loads, operate smoother, perform more difficult tasks, and last longer. H & H Specialties has continually worked with architects, consultants and users in designing products to meet these requirements.

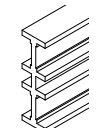
Our products are stocked and sold by established dealers throughout the United States, Canada, Mexico and many other countries, providing local sources for the supply, installation and maintenance of our equipment. In addition, the factory's design and manufacturing capabilities are available to create custom modified equipment for special applications.

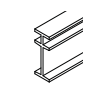

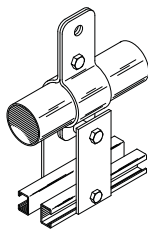
CURTAIN TRACK SELECTION GUIDE

| Model No. | Cross Section | Isometric View | Recommended Working Load ^{1,2} | Carrier Length ³ | COMPLETE Track Weight | Usage |
|--|---|---|---|---|--|--|
| | | | per carrier | inches | lb/ft | |
| 101S 116S |  1-3/4"W x 2"H |  | 3 5 | 1-3/16 1-5/16 | 1.9 2.0 | Standard-duty straight track for curtains up to 40 feet. Can be walk-along or cord operated. |
| 201S 228S |  1-3/4"W x 2"H |  | 5 10 | 1-3/4 | 2.1 2.2 | Black finished, medium-duty straight track for curtains up to 48 feet. Can be walk-along or cord operated. |
| 301A 316A 328A |  1"W x 2-1/2"H |  | 5 7 7 | 1-5/16 | 1.5 1.6 1.6 | Standard-duty curved or straight track for curtains up to 60 feet. Can be walk-along or cord operated. Cord operated tracks cannot be reverse curved. Ideal for TV studios or stage use. |
| 401S 416S 416P 418S 418P 428S |  2-5/8"W x 2-3/4"H |  | 6 25 25 25 25 15 | 1-5/8 2-1/16 2-1/16 2-1/16 2-1/16 2-1/16 | 3.2 4.0 4.3 4.0 4.3 3.5 | Model 401 straight track for curtains up to 60 feet. Can be walk-along or cord operated. Model Nos. 416, 418, and 428 for curtains of almost any length. |
| 501C 516C |  1-5/8"W x 3-1/4"H |  | 25 25 | 2-1/4 | 4.2 4.2 | Heavy-duty curved or straight track for curtains of almost any length. Can be reverse curved for walk-along or cord operated use. Ideal for TV studios, stage, and auditorium dividers. |
| 601A 616A 628A |  1"W x 3-3/8"H |  | 5 7 7 | 1-5/16 | 2.5 2.6 2.6 | Medium-duty curved or straight track for curtains up to 60 feet. Walk-along or cord operated. Cord operated tracks cannot be reversed curved. |
| 701A 716A 728A |  5/8"W x 1-11/16"H |  | 2 4 4 | 1-1/16 | 0.6 0.7 0.7 | Light-duty curved or straight track for curtains up to 40 feet. Walk-along use only. |
| 818-1 |  |  | 25 | 2-1/8 | 4.6 | Heavy-duty curved or straight open style track for TV studios. Available in single and double configurations for walk-along use only. |
| 1018S |  3-1/4"W x 9-3/8"H | | 25 | 2-1/4 | 7.5 | Heavy-duty, exceptionally quiet open style straight track for professional theatre and TV studio use. Cord operated only. |

1. Recommended working load per carrier for cord operated tracks. Total weight of drapery, track length, and model used will determine ease of operation of the track system. Curtain weight per carrier is based upon a typical spacing of 12" on center across the top of the curtain.
2. Hanger spacing dependent on carrier load, see catalog for recommendations. Track hangers must be supported from overhead structure by appropriate means.
3. Per carrier. To determine stacking space, see explanation in catalog.



CURTAIN MACHINE SELECTION GUIDE

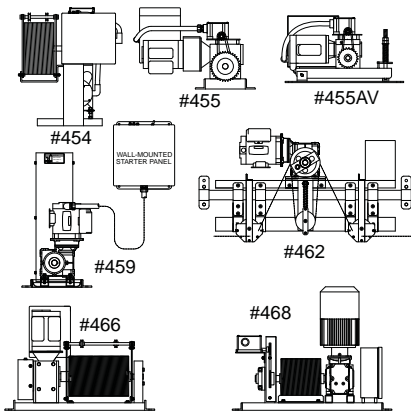

H & H Specialties manufactures a complete line of machines for motorizing stage and acoustic curtains. Draw machines for operating curtain tracks are available with grooved winding drums, traction drives, or sprocket drives. Lift Machines for masking and lift curtains are available with grooved winding drums or sprocket drives. All machines are equipped with magnetic reversing starters and limit switches for fully automatic operation between preset curtain positions. An unlimited number of remote control stations can be utilized, in addition to the local controls included on each machine. Each single phase motor is instantly reversing, eliminating the need for safety time-delay relays. All curtain machines are equipped with low voltage control circuits.

Most curtain machines may be modified with optional features. Contact the factory for further information.

| MODEL NO. | DRIVE STYLE | MACHINE TYPE | HP | INPUT VOLTS | PHASE | AMPS | OUTPUT TORQUE (lb-in) | CABLE SPEED (ft/min) | LIFT CAPACITY (lbs) | MAX. TRAVEL (ft) |
|-----------|-------------|---------------------|-------|-------------|-------|------|-----------------------|----------------------|---------------------|------------------|
| 454 | Drum | Draw | 1/3 | 115 | 1 | 4.8 | 487 | 89 | - | 45 |
| | | | 1/2 | 115 | 1 | 6.4 | 731 | 89 | - | 45 |
| | | | 3/4 | 115 | 1 | 11.2 | 1035 | 94 | - | 45 |
| | | | 1 | 115 | 1 | 13.2 | 1054 | 128 | - | 45 |
| 454VS | Drum | Variable Speed Draw | 1/2 | 115 | 1 | 12.0 | 527 | 26-130 | - | 45 |
| | | | 1 | 115 | 1 | 15.0 | 1054 | 26-130 | - | 45 |
| 455AV | Sprocket | Masking | 1/3 | 115 | 1 | 4.8 | 442 | 36 | 125 | 12 |
| 455 | Sprocket | Lift | 3/4 | 208 | 3 | 3.0 | 707 | 64 | 220 | 32 |
| | | | 1 | 208 | 3 | 4.1 | 943 | 64 | 295 | 32 |
| | | | 1-1/2 | 208 | 3 | 4.7 | 1480 | 99 | 370 | 40 |
| 459 | Traction | Draw | 1/3 | 115 | 1 | 4.8 | 254 | 78 | - | Unlimited |
| | | | 1/2 | 115 | 1 | 6.4 | 381 | 78 | - | Unlimited |
| | | | 3/4 | 115 | 1 | 11.2 | 571 | 83 | - | Unlimited |
| | | | 1 | 115 | 1 | 13.2 | 695 | 99 | - | Unlimited |
| 462 | Traction | Track-Mounted Draw | 1/3 | 115 | 1 | 4.8 | 254 | 78 | - | Unlimited |
| | | | 1/2 | 115 | 1 | 6.4 | 381 | 78 | - | Unlimited |
| | | | 3/4 | 115 | 1 | 11.2 | 571 | 83 | - | Unlimited |
| | | | 1 | 115 | 1 | 13.2 | 695 | 99 | - | Unlimited |
| 462VS-1 | Traction | Variable Speed Draw | 1 | 115 | 1 | 15.0 | 574 | 26-130 | - | Unlimited |
| 462VS-2 | Traction | Variable Speed Draw | 2 | 208-240 | 3 | 8.6 | 634 | 52-260 | - | Unlimited |
| 463 | Traction | Draw | 1/2 | 115 | 1 | 6.4 | 381 | 78 | - | Unlimited |
| | | | 3/4 | 115 | 1 | 11.2 | 571 | 83 | - | |
| 466 | Drum | Draw | 1/2 | 115 | 1 | 6.4 | 471 | 85 | - | 80 |
| | | | 3/4 | 115 | 1 | 11.2 | 707 | 90 | - | 80 |
| | | | 1 | 115 | 1 | 13.2 | 943 | 90 | - | 80 |
| 466VS-1 | Drum | Variable Speed Draw | 1 | 115 | 1 | 15.0 | 761 | 25-126 | - | 80 |
| 468 | Drum | Lift | 3/4 | 208 | 3 | 3.0 | 834 | 73 | 185 | 36 |
| | | | 1 | 208 | 3 | 4.1 | 1112 | 73 | 250 | 36 |
| | | | 1-1/2 | 208 | 3 | 4.7 | 1480 | 111 | 330 | 45 |

COUNTERWEIGHT RIGGING

The type of counterweight rigging system furnished on a stage is dependent on facility use, operational requirements, building configuration, and cost. Actual equipment required will be determined by these design parameters. The drawing below represents a typical cross-section through a stage looking toward the proscenium and identifies the major system components.

H & H Specialties Inc. has designed each of its rigging products with careful consideration given to safety, ease of operation, and longevity. Catalogs describing our standard drapery tracks and stage rigging components are available in both printed and electronic form, as well as assistance in developing customized equipment for specific applications.

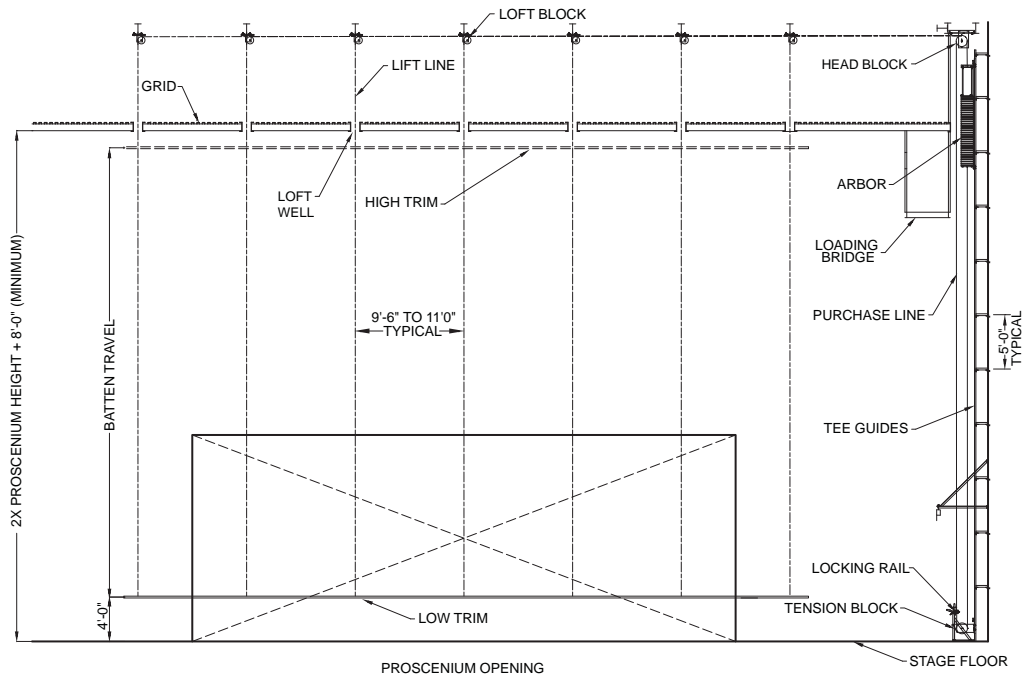

Typical Underhung Counterweight System



For further information contact the factory:



14850 Don Julian Road, Suite B • City of Industry, CA 91746
 626 575-0776 • 800 221-9995
 Fax 626 575-3004 • www.hhspecialties.com

